

# CF7512i Cassette Disassembly Instructions



Cassette  
Facia



Cassette  
Spine

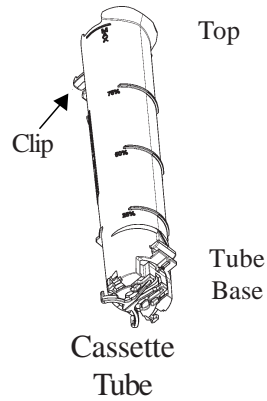

**To disassemble:**

- 1) Remove the cassette fascia from the spine. To do so, dislodge bottom left of cassette fascia from spine. Once bottom is dislodged, slide down cassette fascia so it unlocks from spine( as shown in figure 1).
- 2) Lift up the left side of the cassette fascia ( as shown in figure 2) and remove.
- 3) Turn to the back side of the spine. Each tube is held to the spine by a clip on the top, rear of the spine. Use a device, such as the back of a pen or pencil to pop the clip loose ( as shown in figure 3).
- 4) Once the clip is loose, the top of the tube hinges out and dislodges from the hinge slot located at the base of the tube(as shown in figure 4).
- 5) Repeat procedures for all five tubes if needed.

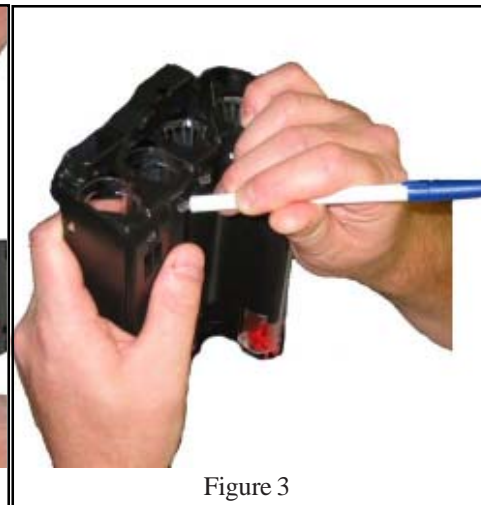
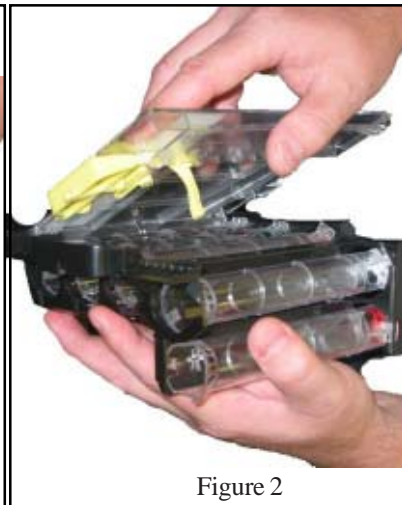
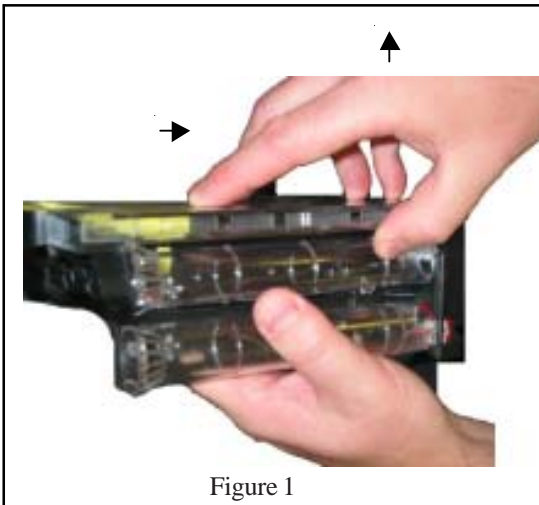
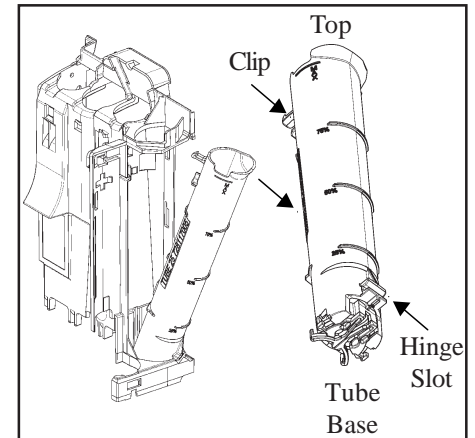



# CF7512i Cassette Assembly Instructions



## Prior to assembly, follow these instructions:

You must always include at least one 5c tube in all custom configured cassettes.

Do not place the \$1 tube in position A or B.

Do not place the 25 cent tube in position B.

Do not place the 10 cent tube in position E

Coin	Tube Base Color	Max Fill (\$)	Manual Fill(\$)	Tube Position – OK
5c	Red	77 (3.85)	87 (4.35)	A,B,C,D,E,
10c	White	115 (11.50)	127 (12.70)	A,B,C,D,
25c	Black	84 (21.00)	96 (24.00)	A,C,D,E,
\$1	Blue	69 (69.00)	81 (81.00)	C,D,E,



Cassette  
Facia

## Assembly Instructions:

1) Place selected tubes in desired positions. Reference the chart above for allowable tube positioning.

Insert the slot at the bottom of each tube into the spine of the cassette and hinge the top till the clip snaps into the spine (see figure 1).

2) Insert the right side tabs of the cassette facia into the hinge slots located on the cassette spine. Once inserted, hinge the left side closed. Then slide the cassette facia up to lock it into place (see figure 2).

3) Place cassette label on the cassette facia. Write the coin value for each tube on the label. If the cassette is a custom cassette, write "CD" on the label for cassette model. Insert the cassette into your coin manager.

4) If your tube locations match tube locations of a pre-programmed cassette (see chart to the right), press the yellow menu button, select the cassette option and enter the respective Key Code (i.e. "AA"). The display will ask you to accept/cancel the change. Once you accept the change press OK to complete the operation.

## How to program custom cassettes:

To route the coins to the proper tubes, press the yellow menu button, select the cassette option, Insert a nickel into the top of the coin manager. Select all tube locations (A-E) where you placed a nickel tube. Follow the same procedure with remaining coins for which a tube has been assigned in your custom cassette. Once all letters on the display have been replaced by a coin denomination press the next button. The display will ask you to accept/cancel the change. Once you accept the change press OK to complete the operation.

## Pre-Programmed USA Cassettes

Key Code	Tube A	Tube B	Tube C	Tube D	Tube E
AA	10	5	25	25	5
AB	10	5	25	\$1	5
BA	25	5	25	25	25
BB	10	5	10	25	5
CC	Custom cassette 1 - defined in factory or by service tool.				
CD	Custom cassette 2 - define yourself using cassette teach.				
DAC	25	5	\$1	\$1	25
DCA	25	10	25	\$1	5
DCB	25	10	\$1	\$1	5
DCC	25	10	25	25	5
DCD	5	10	10	10	5
DCE	10	10	10	10	5

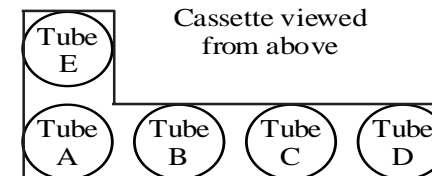

Figure 1

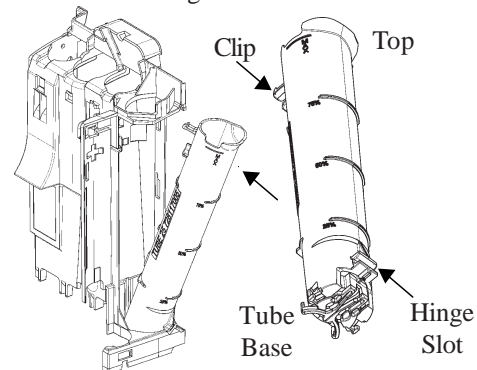

Figure 2

