

MEI Bill Acceptor *Series 3000*

Series 3000 Bill Programming Module (BPM)

The purpose the BPM is to flash download new software into the Series 3000 Bill Acceptors that already have the new \$20 software. All Series 3000 Bill Acceptors have flash download capability.

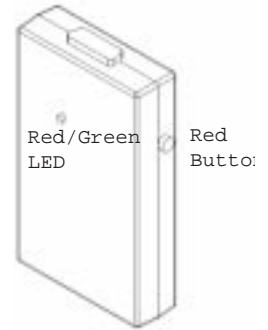

Download Procedure:

1. Apply power to the Series 3000 Bill Acceptor then connect the BPM to the 18-pin connector of the Series 3000 Bill Acceptor.
2. Press the Red Button on the BPM till the Green LED illuminates to indicate power to the BPM.
3. The Green LED on the BPM will flash, then go solid. If the Green LED does not light, turn to the Troubleshooting Section on reverse side.
4. Power down the Series 3000 Bill Acceptor and reconnect the original cables.
5. Resupply power to the Series 3000 Bill Acceptor.
6. Place the New Currency Ready Label on the Bill Acceptor to indicate the unit has been updated.

Connections:

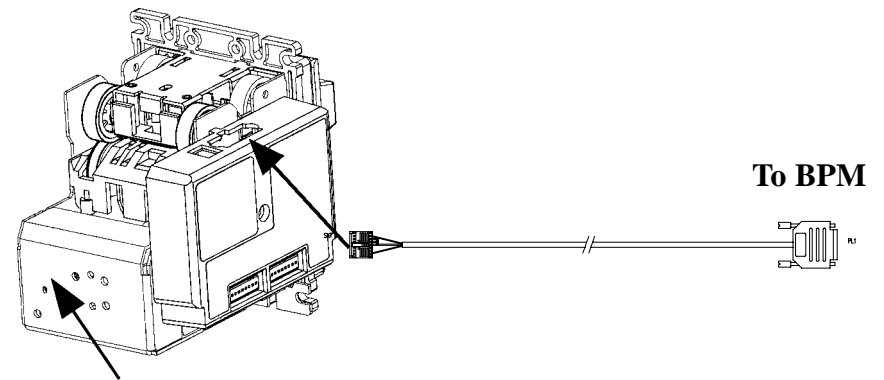

New \$ Currency Ready Label

Troubleshooting:

Flash Code	Description of Code	Solution
Solid Green	Bill Acceptor is Already Programmed	Bill Acceptor already has the software revision installed.
Solid Red	BPM Not Connected to a Bill Acceptor	Check to ensure the harnesses between the BPM and the Bill Acceptor are seated properly.
Solid Amber/ No LED Illuminates	Low Battery	Change the batteries. NOTE: MEI does not recommend downloading new software with low batteries. The BPM takes 2 AA batteries. The battery panel is located in back of BPM.
1 Long Red Flash	No Credits	BPM may be out of credits. Follow procedure below to check how many credits are left in BPM.
1 Short Red Flash	Invalid Product	The BPM does not have the revision software installed to download the model Bill Acceptor you are trying to upgrade. Example: A BPM for a Series 3000 Bill Acceptor cannot be used to upgrade the software in a Series 2000 Bill Acceptor or the new \$20 software is not installed in the Series 3000 Bill Acceptor.
2 Short Red Flashes	Unrecoverable Error when Downloading	BPM failed during the download process. With the BPM still connected cycle power to Bill Acceptor (unit may not do a run and stack) then try again.
3 Short Red Flashes	BPM is defective	BPM will need to be returned to MEI for service.
Flash Codes will repeat for 10 seconds.		

Check Number of Credits in BPM:

Disconnect BPM from Bill Acceptor. Press and hold the Red Button. The LED will first be solid red; then after 3 seconds the LED will start flashing a code to show how many credits are left in the BPM (see below). The flash code will repeat continuously while the Red Button is held down. **NOTE:** A credit is only taken from the BPM when a download is successful.

Red/Green Repeatedly Represents over 100 Credits
 Green Represents 10 credits for each flash
 Red Represents 1 credit for each flash

Examples:

Credits	Green Flashes	Red Flashes
5	0	5
17	1	7
30	3	0

Questions should be directed to MEI Technical Support at 1-800-345-8172 or our web site: www.meiglobal.com .